

CONSEW[®]

**Model
7360R-1**

1. MAIN SPECIFICATIONS

MODEL	M	H	B
MAX. SEWING SPEED (S. P. M)	5000	3500	3000
STITCH LENGTH	5 mm	7 mm	
PRESSER FOOT LIFT	BY HAND	5 mm	
	BY KNEE	13 mm	
NEEDLE	DB x1 11 # - 18 #	DP x5 18# - 22#	
REVERSE SEWING DEVICE	yes		
LUBRICATION	automatic lubrication		

2. RUN - IN OPERATION (Fig. 1)

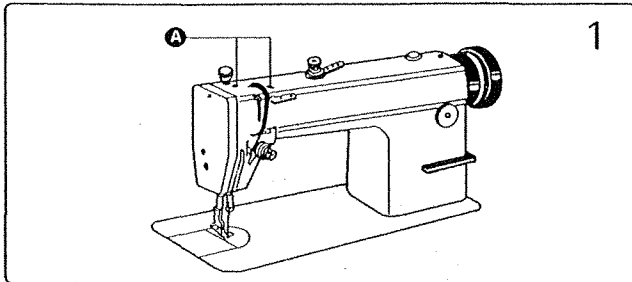

Before putting a new machine into operation, run-in operation is required for a new machine. Remove the red plugs (A) on the top of the arm and replenish sufficient amount of oil, then lift the presser foot and run the machine at a low speed of 2000 spm to check oil distributing condition through oil check window. When lubricating is normal, keep the machine running-in at the speed of 2000 - 2500 spm for 30 minutes, then increase the running speed gradually. After one month run-in operation, the machine can be run at a high speed of 5000 spm under normal working condition.

3. OIL FILLING (Fig. 2)

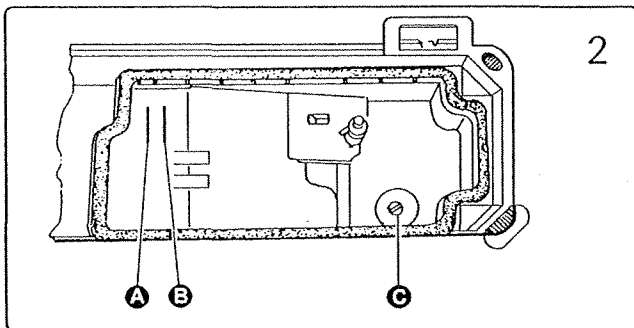

1). The oil amount in the oil reservoir is controlled through the reference marks A and B shown in Fig. 2. The mark A indicates the max. oil amount level, the mark B for the min. oil amount level. If the oil amount level is under the mark B, replenish the oil reservoir with oil in time.

2). When filling oil, loosen the oil draining screw (C), drain off the remaining oil in the oil reservoir completely, clean the oil reservoir and tighten the oil draining screw (C), then fill the oil reservoir with fresh oil.

4. ROTATING HOOK OIL AMOUNT ADJUSTMENT (Fig. 3)

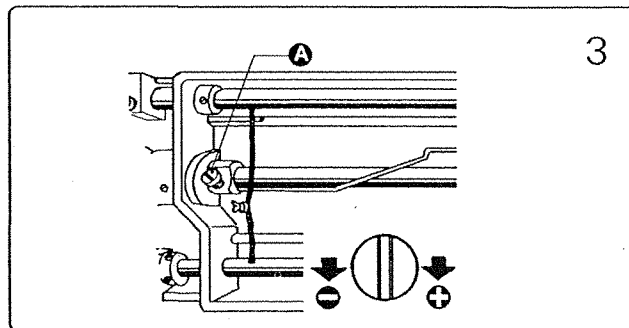

Adjust the oil amount of the rotating hook by turning the oil amount adjusting screw (A). Turn the screw (A) clockwise (in the "+" direction) to increase the oil amount; turn it counter-clockwise (in the "-" direction) to decrease the oil amount.

5. OIL PUMP ADJUSTMENT (Fig. 4)

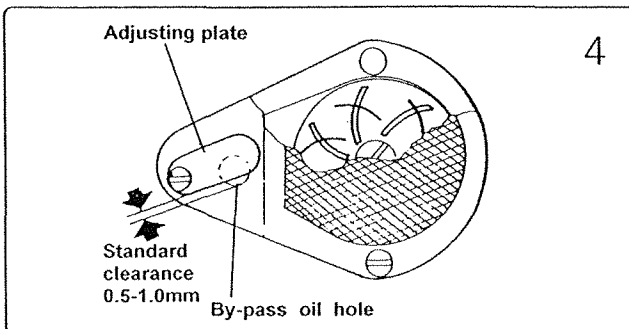

In ordinary operation, adjustment is not required for the oil pump. If oil splashing does not occur in the oil check window when the machine runs at a low speed (approx. 2000 spm), close the clearance of the bypass oil hole.

6. NEEDLE INSTALLATION (Fig. 5)

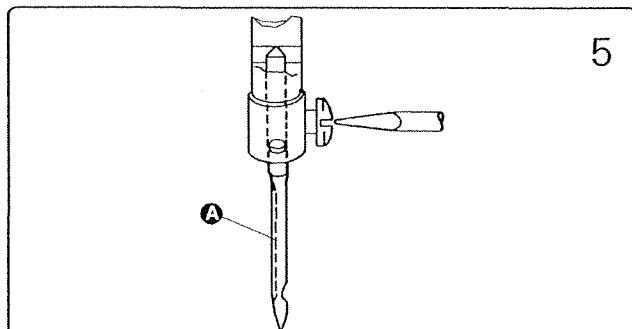

Turning the balance wheel to lift the needle bar to the upper end of its stroke. Loosen the needle clamp screw while keeping the long groove of the needle leftward, fully insert the needle shank up to the bottom of the needle socket, then tighten the needle clamp screw.

7. CONNECTION OF THE CLUTCH LEVER WITH THE PEDAL (Fig. 6)

- 1) . The optimum tilt angle of pedal is approximately 15 deg.
- 2) . Adjust the clutch so that the clutch lever (C) align with the draw bar (B) as shown in Fig. 6
- 3) . The machine pulley should rotate counter - clockwise when viewed from the outside of it. The rotating direction of the motor pulley can be reversed by turning the plug of the motor at 180 deg.
- 4) . Adjust the tension of O - belt (F) by moving the motor up and down. The proper tension of the O - belt is a slack of 10 - 20 mm when the belt is depressed at the center of the belt by finger.

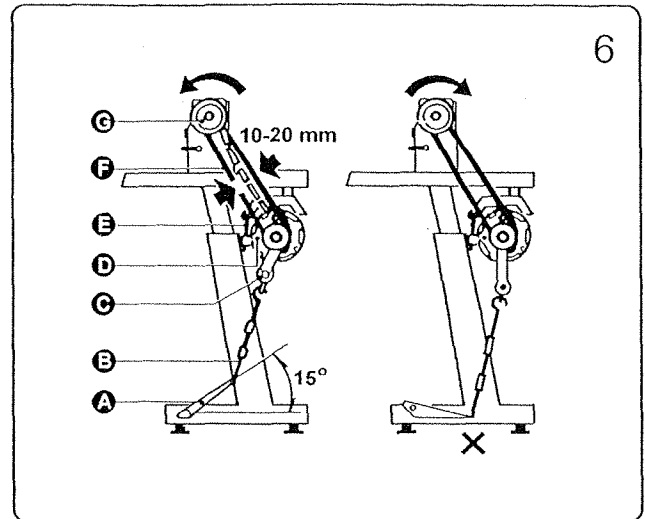

8. BELT COVER INSTALLATION (Fig. 7)

Install the belt cover for the sake of safety.

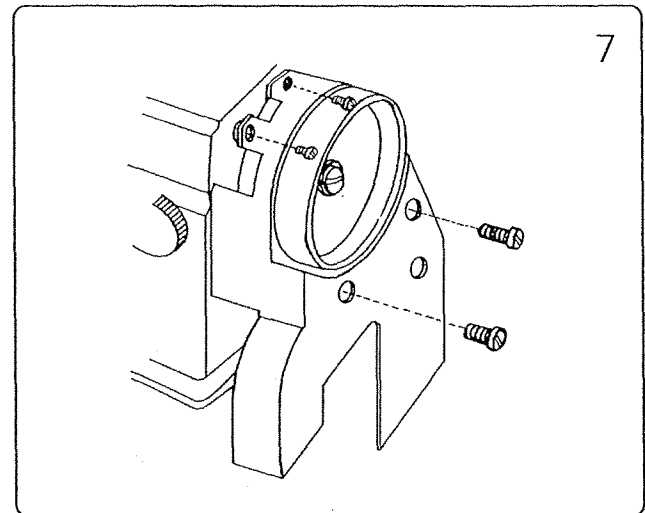

9. ADJUST THE OPENING TIME OF THE TENSION DISCS (Fig. 8)

Within the presser foot lift range of 2-7 mm, the opening time of the tension discs can be adjusted as follows:

- 1) . Remove the rubber plug from the back of the arm and loosen the screw (A) of the knee lift lever (left).
- 2) . Move the tension releasing cam (D) leftward for earlier opening or rightward for later opening . It will facilitate the adjustment if putting a block under the presser foot lift.

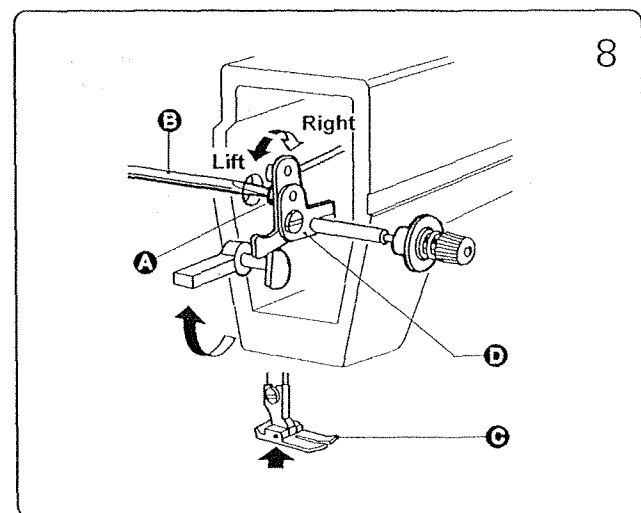

10. THREADING (Fig. 9)

To thread the needle thread, raise the needle bar to the upper end of its stroke, lead the thread from the spool and perform threading as shown in Fig. 9. To draw the bobbin thread, hold the end of the needle thread and turn the balance wheel to lower the needle bar and then lift it to its highest position. Pull the ends of needle thread and bobbin thread forward under presser foot.

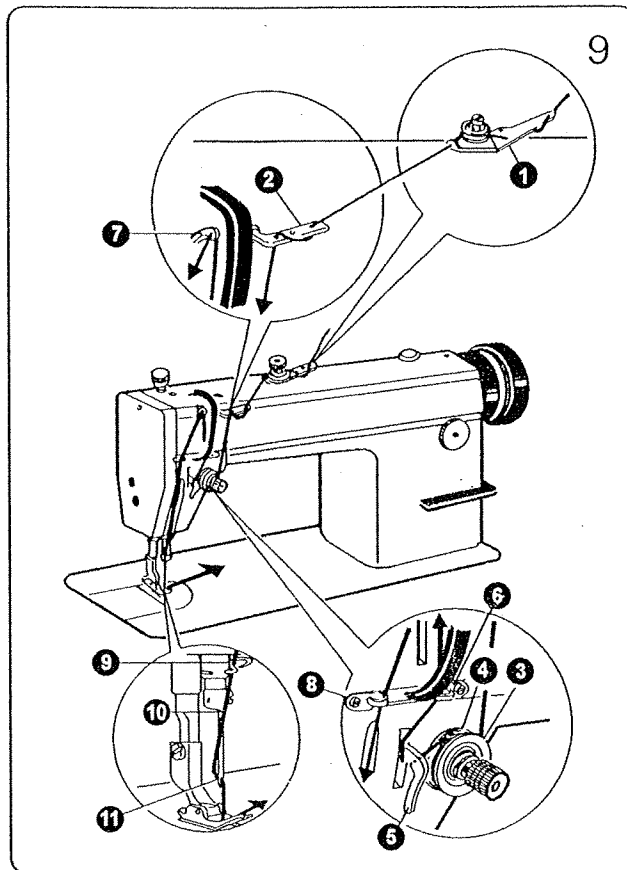

11. WINDING ADJUSTMENT (Fig. 10)

The bobbin winder pulley should align with the V-belt and there should be some clearance between them. When the bobbin winder stop latch lever is depressed, the V-belt should be in touch with the bobbin winder pulley in order that the bobbin winder puller can be driven by the V-belt.

The thread wound on the bobbin should be neat and tight, if not tight, adjust the winding tension by turning the tension stud nut (A) of the bobbin winder tension bracket. When the thread wound on the bobbin does not present a cylindrical shape as shown in Fig. 10(a), loosen the set screw (B) of the bobbin winder tension bracket and move the bracket (C) leftward or rightward. If the thread is wound as shown in the figure (b), move the bracket rightward or if wound as shown in the figure (c), move it leftward. After positioning the bracket adequately, tighten the set screw (B).

Do not overfill the bobbin. The optimum wound length of the thread will fill about 80% of the bobbin capacity. This can be adjusted by the screw (E) of the bobbin winder stop latch.

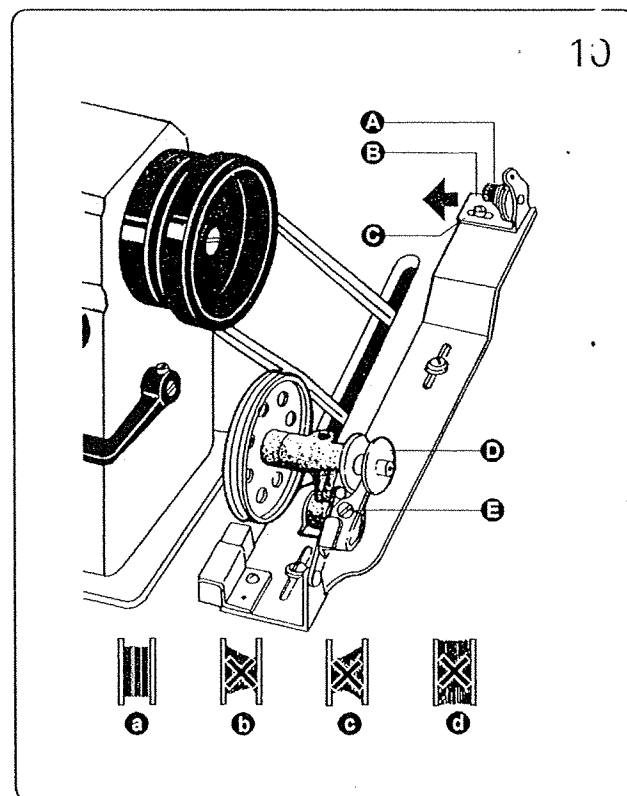

12. ADJUST THE PRESSURE OF PRESSER FOOT (Fig. 11)

Pressure of the presser foot is adjusted in accordance with thickness of materials to be sewn.

First loosen the lock nut (A), for heavy materials, turn the pressure regulating thumb screw as shown in Fig. 11(a) to increase the pressure, while for light materials, turn the pressure regulating thumb screw as shown in Fig. 11(b) to decrease the pressure, then tighten the lock nut (A).

The pressure of the presser foot is recommended to be less as long as normal feeding is ensured.

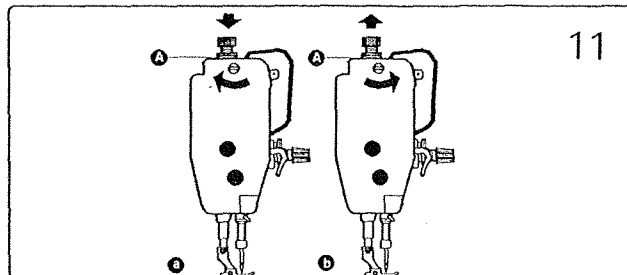

13. THREAD TENSION ADJUSTMENT (Fig. 12, 13, 14)

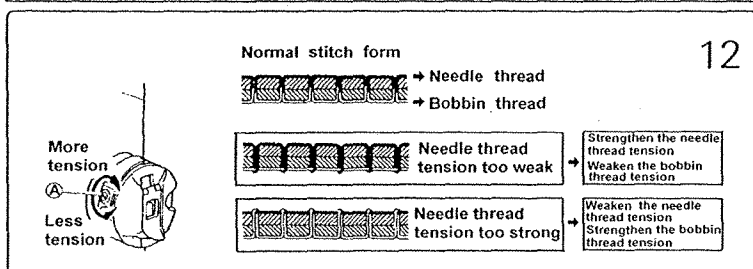

Thread tension should be determined in accordance with the stitches obtained by adjusting the tension of the bobbin thread and needle tension (Fig. 12).

The tension of the bobbin thread: to be adjusted by turning the tension spring regulating screw of the bobbin case. After adjusting, insert the bobbin into the bobbin case and hold the end of the thread from the bobbin case to hang the bobbin case, if the bobbin case falls slowly and evenly, the proper tension of the bobbin thread is obtained.

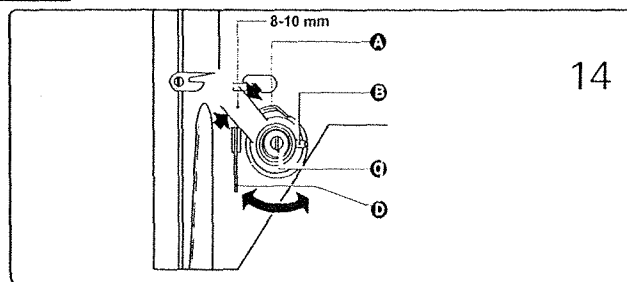
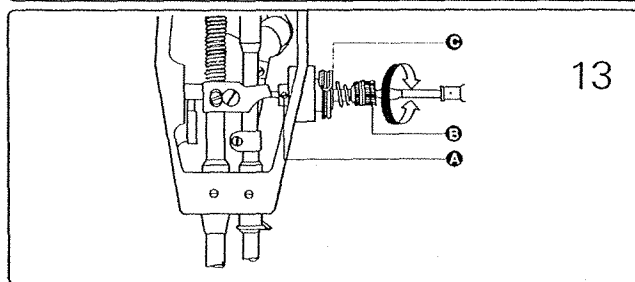

The tension of the needle thread: to be adjusted by turning the thumb nut.

The stroke of the thread take-up spring runs from 8mm to 10mm. When sewing very thin fabrics, reduce the thread take-up spring tension and increase the thread take-up spring stroke, whereas increase the thread take-up spring tension and reduce the thread take-up stroke when sewing very thick fabrics.

Adjusting the thread take-up spring tension: (Fig. 13) First loosen the set screw (A), turn the tension stud (B) counter-clockwise to decrease the tension of the thread take-up spring (C) to zero, then turn the tension stud (B) clockwise till the spring (C) comes to the notch of the tension regulating bushing, and again turn the tension stud (B) halfway back (counter-clockwise). After the adjustment, tighten the set screw (A).

Adjusting the thread take-up spring stroke: (Fig. 14) loosen the set screw (B), turn the stud (C) clockwise to increase the stroke or turn the stud (C) counter-clockwise to decrease the stroke. After the adjustment, tighten the set screw (B).

14. ADJUST THE SYNCHRONIZATION OF THE NEEDLE WITH ROTATING HOOK (Fig. 15, 16)

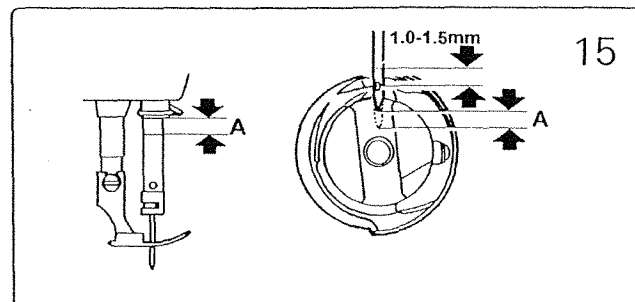

When lifting the needle bar from its lowest position of the stroke to the distance A, the hook point D of the bobbin should align with the center line of the needle and be 1.0 - 1.5 mm above the upper end of the needle eye. (Fig. 15)

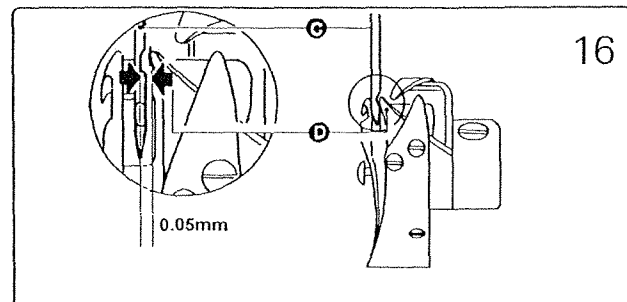

The clearance between the bottom of the needle notch and the hook point should be 0.05 mm (Fig. 16).

MODEL	M	H	B
A	2.2mm	2mm	2.4mm

15. ADJUSTMENT OF STITCH LENGTH AND REVERSE FEEDING (Fig. 17)

The stitch length can be adjusted by turning the dial (A). The figures on the face (B) of the dial show the stitch length in mm.

The reverse feeding starts when the reverse feed lever (C) is depressed, the machine will feed forward again if the reverse feed lever is released.

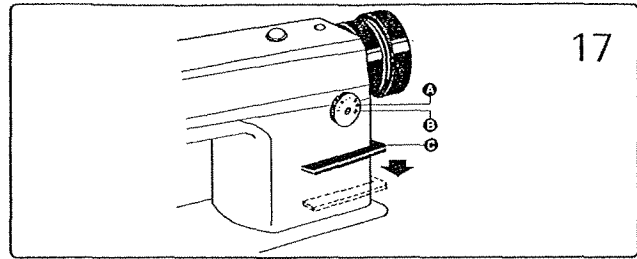

16. ADJUST THE SYNCHRONIZATION OF THE NEEDLE MOTION WITH THE FEED MOTION (Fig. 18, 19)

To adjust the feed dog position (G), first should release the two set screw (F) and turn around the balance wheel by hand. When the needle (A) point reaches the surface of the throat plate (B), the top of the feed dog (C) should be flush with the throat plate surface.

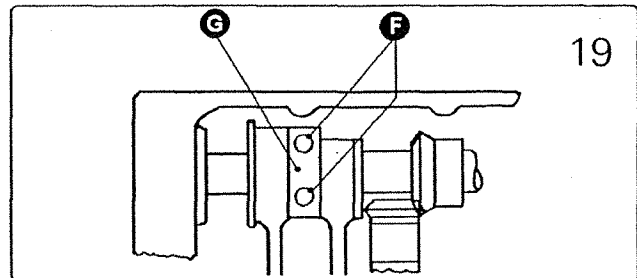
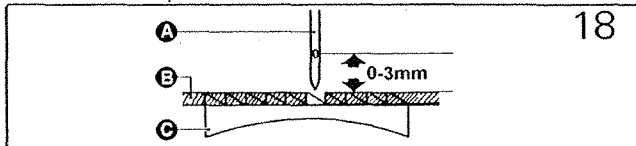

17. STITCH LENGTH ERROR ADJUSTMENT (Fig. 20)

Loosen screw (A) to adjust the stitch length adjusting cam (B). Turn it rightward to narrow the stitch length as forward sewing, and widen it as reverse sewing; turn it leftward to widen the stitch length as forward sewing, and narrow it as reverse sewing.

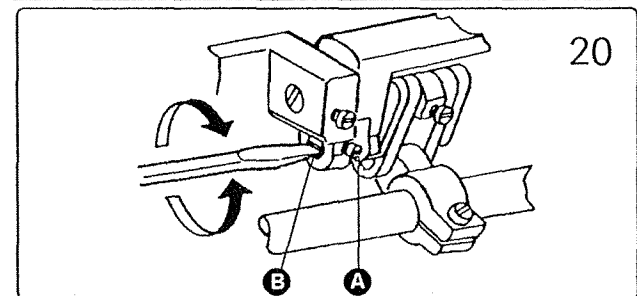

18. FEED DOG HORIZONTALITY ADJUSTMENT (Fig. 21)

The feed dog is horizontal and 0.8 mm above the throat plate. When the sewing condition requires the tilting of the feed dog, then adjust it.

- 1). Loosen the feed support crank shaft screw (A);
- 2). Press with a screwdriver in the groove of the feed dog support crank eccentric shaft so that the eccentric shaft can turn right and left;
- 3). Tighten the screw (A).

To lift the front part of the feed dog can prevent sewing material from sliding away and prevent the bobbin thread from breaking.

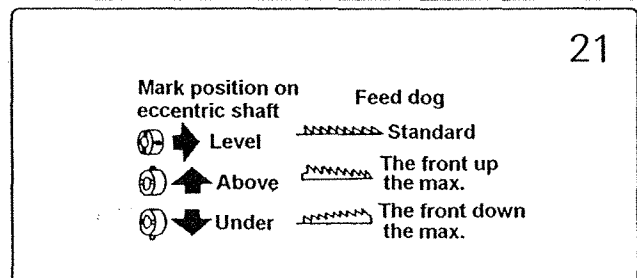

19. THREAD TAKE - UP LEVER OIL SUPPLY ADJUSTMENT (Fig. 22)

Before the machine is carried away from the factory, the thread take - up lever oil supply adjusting pin has already been adjusted in the proper state and the user doesn't need the readjustment. As the oil supply amount of the thread take - up lever is too large or too small, the adjustment is needed.

Adjust as the followings:

When the dot mark on the oil adjusting pin is the upper position, the oil is the maximum. (Fig. a)

When the dot mark on the oil adjusting pin is the lower position, the oil is the minimum. (Fig. b)

Turn the adjusting pin to a certain degree with a screwdriver to make it reach the necessary oil amount position (Fig. c)

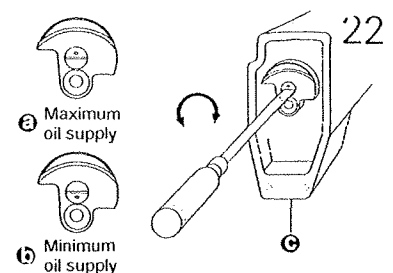

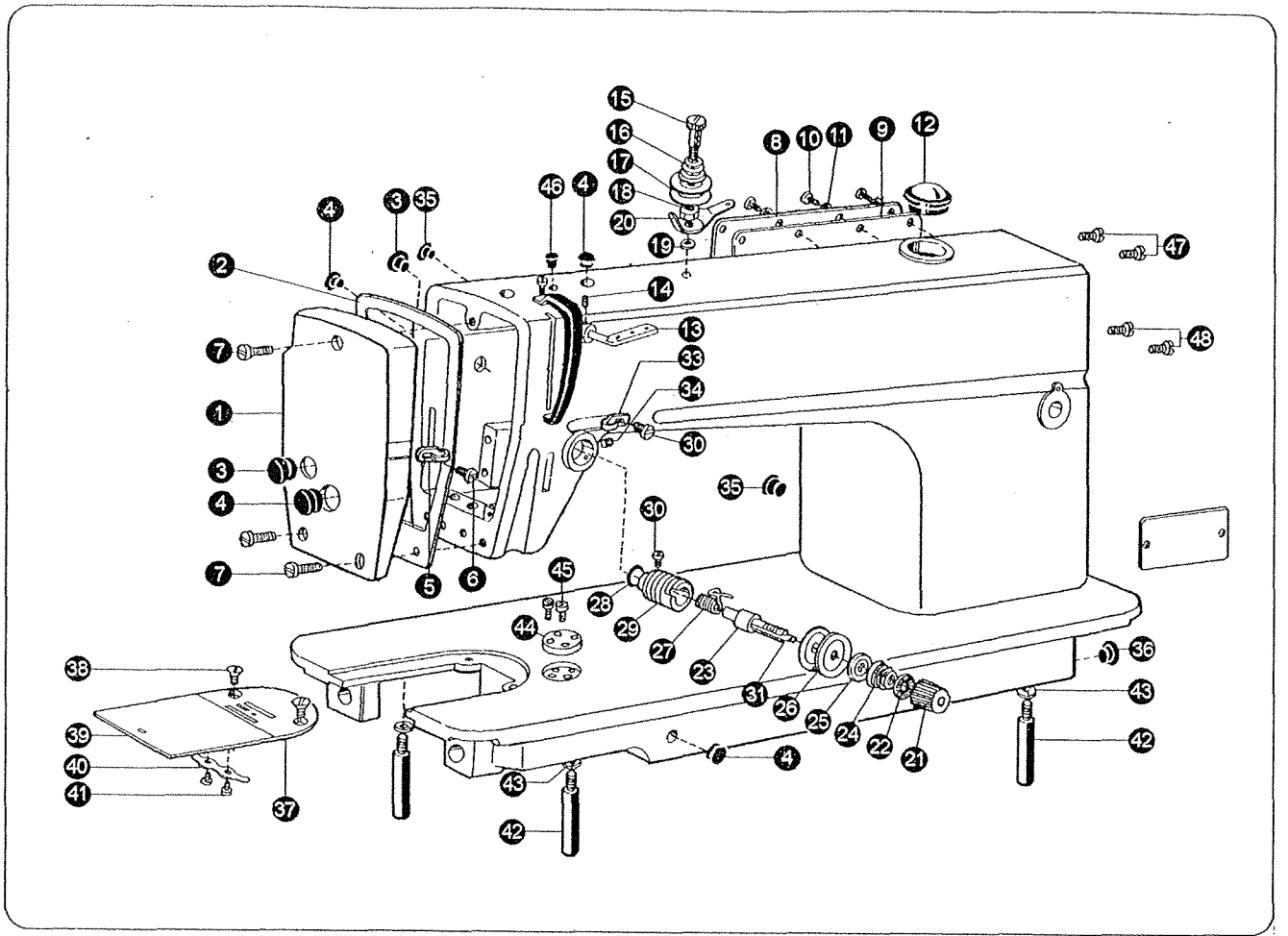

1. ARM BED AND ITS ACCESSORIES

No.	Ref. No.	Description	Pcs.		
			M	H	B
1	124T1 - 002	Face plate	1	1	1
2	124T1 - 003	Gasket for Face plate	1	1	1
3	22T1 - 003C3	Rubber plate	1	1	2
4	22T1 - 003C4	Rubber plate	4	4	4
5	22T1 - 003C5	Thread guide on face plate	1	1	1
6	22T1 - 003C6	Thread guide screw	1	1	1
7	22T1 - 004	Face plate screw	3	3	3
8	22T1 - 005D1	Back plate	1	1	1
9	22T1 - 005D2	Gasket for back plate	1	1	1
10	22T1 - 006	Set screw	8	8	8
11	22T1 - 007	Washer	8	8	8
12	22T1 - 008H	Oil check window	1	1	1
13	36T2 - 004	Three hole thread guide	1	1	1
14	36T2 - 005	Set screw	1	1	1
15	22T1 - 009E1	Screw	1	1	1
16	36T2 - 006D3	Spring for pre - tension	1	1	1
17	22T1 - 009E3	Discs for pre - tension	2	2	2
18	22T1 - 009E4	Washer	1	1	1
19	GB896 - 76	Spring washer	1	1	1
20	22T1 - 009E5	Thread guide for pre - tension	1	1	1
21	124T1 - 003C1	Knub for thread tension regulator	1	1	1
22	22T1 - 012F10	Thumb nut revolution stoper	1	1	1
23	22T1 - 012F1	Thread tension stud	1	1	1
24	124T1 - 003C2	Thread tension spring	1		
	48T1 - 003A1	Thread tension spring		1	1

No.	Ref. No.	Description	Pcs		
			M	H	B
25	22T1 - 012F4	Thread tension releasing disc	1	1	1
26	22T1 - 012F5	Thread tension disc	2	2	2
27	22T1 - 012F6	Thread take up spring	1		
	48T1 - 003A2	Thread take up spring		1	1
28	22T1 - 012F11	Rubber ring	1	1	1
29	22T1 - 012F7	Thread tension regulating bushing	1	1	1
30	22T1 - 012F8	Set screw	1	1	1
31	22T1 - 012F9	Thread tension releasing pin	1	1	1
32	22T1 - 013	Set screw	1	1	1
33	22T1 - 014	Thread guide for arm center	1	1	1
34	22T1 - 003C6	Set screw	1	1	1
35	22T1 - 015	Rubber plug	2	2	2
36	22T1 - 016	Rubber plug	1	1	1
37	36T2 - 008	Needle plate	1		
	48T1 - 004	Needle plate		1	
	78T1 - 006	Needle plate			1
38	22T1 - 020	Needle plate screw	2	2	2
39	22T1 - 021G1	Slide plate	1	1	1
40	22T1 - 021G2	Spring for slide plate	1	1	1
41	22T1 - 021G3	Screw	2	2	2
42	48T1 - 005	Leg	3	3	3
43	GB93 - 76	Washer	2	2	2
44	57T1 - 008	Ruler plate	1	1	1
45	22T2 - 004	Ruler screw	2	2	2
46	22T1 - 017	Red rubber plug	1	1	1
47	22T1 - 006	Screw	2	2	2
48	22T8 - 009	Screw	2	2	2

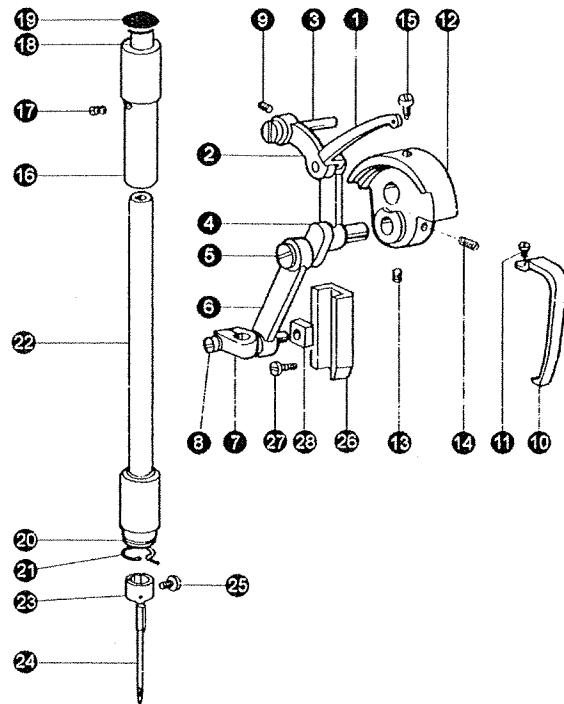

2. NEEDLE BAR AND THREAD TAKE – UP MECHANISM

No.	Ref. No.	Description	Pcs.		
			M	H	B
1	124T2 – 001A1a	Thread take – up lever	1		
	48T2 – 001A1a	Thread take – up lever		1	
	78T2 – 001A1a	Thread take – up lever			1
2	22T2 – 001A2	Thread take – up link	1	1	1
3	22T2 – 001A3	Thread take – up lever hinge pin	1	1	1
4	22T2 – 001A4	Thread take – up crank	1	1	1
	22T2 – 001A5	Needle roller bearing	2	2	2
5	22T2 – 001A6	Set screw(left hand thread)	1	1	1
6	22T2 – 001A7b1	Needle bar link ass.	1		
	48T2 – 001A2	Needle bar link ass.		1	1
7	22T2 – 001A8	Needle bar connecting bar joint	1	1	1
8	22T2 – 001A9	Screw	1	1	1
9	22T2 – 002	Screw	1	1	1
10	36T2 – 007	Take – up lever guard	1	1	
	78T2 – 002	Take – up lever guard			1
11	22T2 – 004	Screw	1	1	1
12	124T2 – 002B1a	Needle bar crank	1		
	124T2 – 002B1b	Needle bar crank		1	1
13	22T2 – 005B2	Screw	2	2	2
14	22T2 – 006	Screw	1	1	1

No.	Ref. No.	Description	Pcs.		
			M	H	B
15	22T2 – 007	Thread take – up crank position screw	1	1	1
16	22T2 – 008	Needle bar bushing (upper)	1	1	1
17	22T2 – 009	Set screw	1	1	1
18	22T2 – 010	Felt plug	1	1	1
19	22T2 – 011	Red rubber plug(Φ8.8)	1	1	1
20	22T2 – 012C1	Needle bar bushing (lower)	1		
	78T2 – 003	Needle bar bushing (lower)		1	1
21	124T2 – 003C1	Thread guide for needle bar bushing	1	1	1
22	22T2 – 014	Needle bar	1		
	48T2 – 003	Needle bar		1	1
23	22T2 – 015	Thread guide for needle bar	1		
	48T2 – 004	Thread guide for needle bar		1	1
24	22T2 – 016	Needle (DB x1) 14#	1		
		Needle (DP x5)		1	1
25	22T2 – 017	Needle clamp screw	1	1	1
26	22T2 – 018	Needle bar connecting link guide	1	1	1
27	22T2 – 019	Set screw	2	2	2
28	22T2 – 020	Slide block	1	1	1

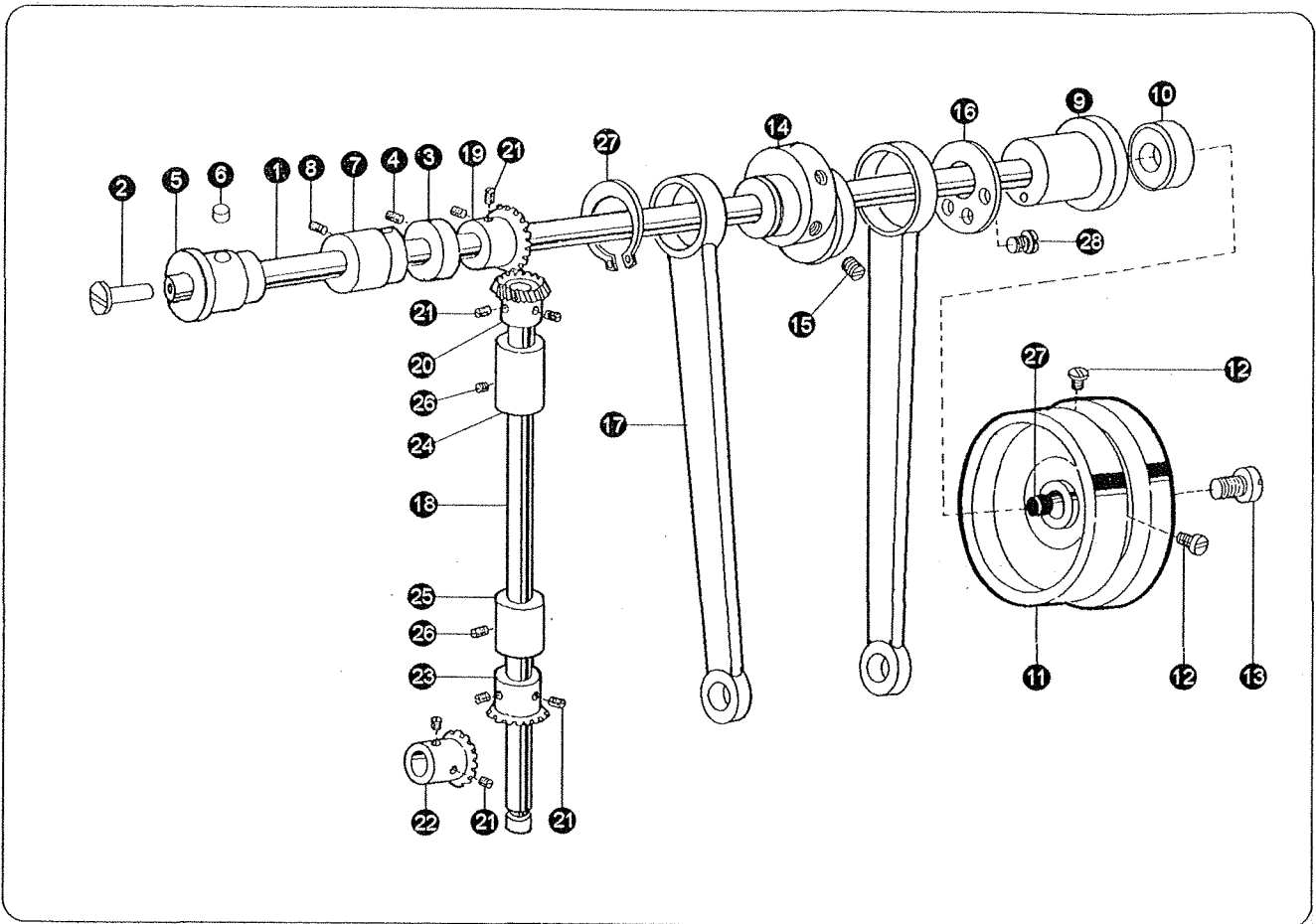

3. ARM SHAFT AND VERTICAL SHAFT MECHANISM

No.	Ref. No.	Description	Pcs.		
			M	H	B
1	124T3 - 001A1	Arm shaft	1	1	1
2	124T3 - 001A2	Adjusting screw	1	1	1
3	22T3 - 002B1	Collar for arm shaft	1	1	1
4	22T3 - 002B2	Set screw	2	2	2
5	124T3 - 002B1	Arm shaft bushing (left)	1	1	1
6	124T3 - 002B2	Oil felt	1	1	1
7	22T3 - 004	Arm shaft bushing (middle)	1	1	1
8	22T2 - 002	Set screw	1	1	1
9	124T3 - 003C1	Arm shaft bushing (right)	1	1	1
10	124T3 - 003C2	Oil seal	1	1	1
11	22T3 - 007C1	Balance wheel	1	1	1
12	22T3 - 007C2	Set screw	2	2	2
13	22T3 - 008	Set screw	1	1	1
14	36T3 - 003	Eccentric wheel	1		
	114T3 - 001	Eccentric wheel		1	1

No.	Ref. No.	Description	Pcs.		
			M	H	B
15	22T1 - 013	Eccentric wheel screw	2	2	2
16	36T3 - 004	Spacer	1	1	1
17	22T3 - 009D1c	Crank rod for feed lifting rock shaft	1	1	1
18	22T3 - 010E1	Vertical shaft	1	1	1
19	22T3 - 010E2a1 - 2	Bevel gear for arm shaft	1	1	1
20	22T3 - 010E2a2 - 2	Bevel gear for vertical shaft (upper)	1	1	1
21	22T2 - 005B3	Set screw	8	8	8
22	22T3 - 010E2b1 - 2	Bevel gear for hook shaft	1	1	1
23	22T3 - 010E2b2 - 2	Bevel gear for vertical shaft (lower)	1	1	1
24	22T3 - 011	Vertical shaft bushing (upper)	1	1	1
25	22T3 - 011	Vertical shaft bushing (lower)	1	1	
	78T3 - 001	Vertical shaft bushing (lower)			1
26	22T2 - 002	Set screw	2	2	2
27	36T3 - 004	Spacer	1	1	1
28	100T6 - 012	Screw	3	3	3
29	22T3 - 001A2	Arm shaft rubber plug	1	1	1

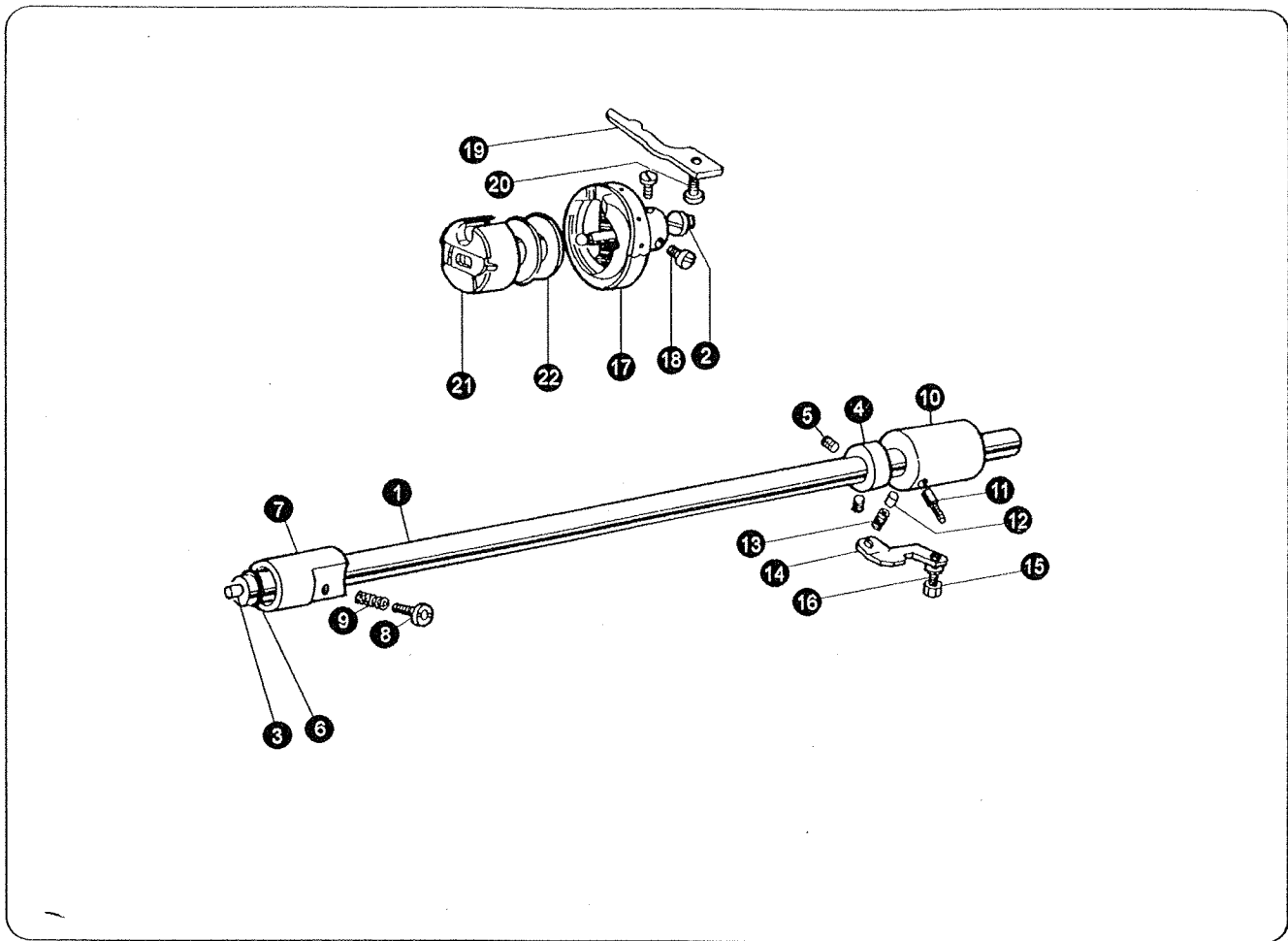

4. ROTATING HOOK MECHANISM

No.	Ref. No.	Description	Pcs.		
			M	H	B
1	36T4 - 008D1	Rotating hook shaft	1	1	
	120T4 - 001	Rotating hook shaft			1
2	22T4 - 001A1a1	Filter screw	1	1	1
3	22T4 - 001A1a2	Filter	1	1	1
4	22T4 - 002B1	Collar for hook shaft	1	1	1
5	22T2 - 009	Set screw	2	2	2
6	22T4 - 003G	Oil seal for rotating hook shaft	1	1	1
7	22T4 - 004	Hook shaft bushing (lift)	1	1	1
8	22T4 - 005	Oil adjusting screw	1	1	1
9	22T4 - 006	Spring for oil adjuster	1	1	1
10	36T4 - 014F1	Hook shaft bushing (right)	1	1	1
11	22T4 - 007C2	Oil pipe for hook shaft bushing	1	1	1
12	36T4 - 015	Plunger	1	1	1
13	36T4 - 016	Plunger spring	1	1	1
14	22T4 - 010	Guide plate	1	1	1
15	22T8 - 009	Screw	1	1	1

No.	Ref. No.	Description	Pcs.		
			M	H	B
16	GB93 - 76	Spring washer	1	1	1
17	22T4 - 011D	Rotating hook	1		
	48T4 - 001A	Rotating hook		1	
	78T4 - 002	Rotating hook			1
18		Screw	2	2	2
19	22T4 - 013	Rotating hook positioner	1		
	48T4 - 002	Rotating hook positioner		1	
	78T4 - 003	Rotating hook positioner			1
20	22T4 - 015	Screw	1	1	1
21	22T4 - 016F	Bobbin case	1	1	
	78T4 - 004F	Bobbin case			1
22	22T4 - 017	Bobbin	1	1	
	78T4 - 005	Bobbin			1

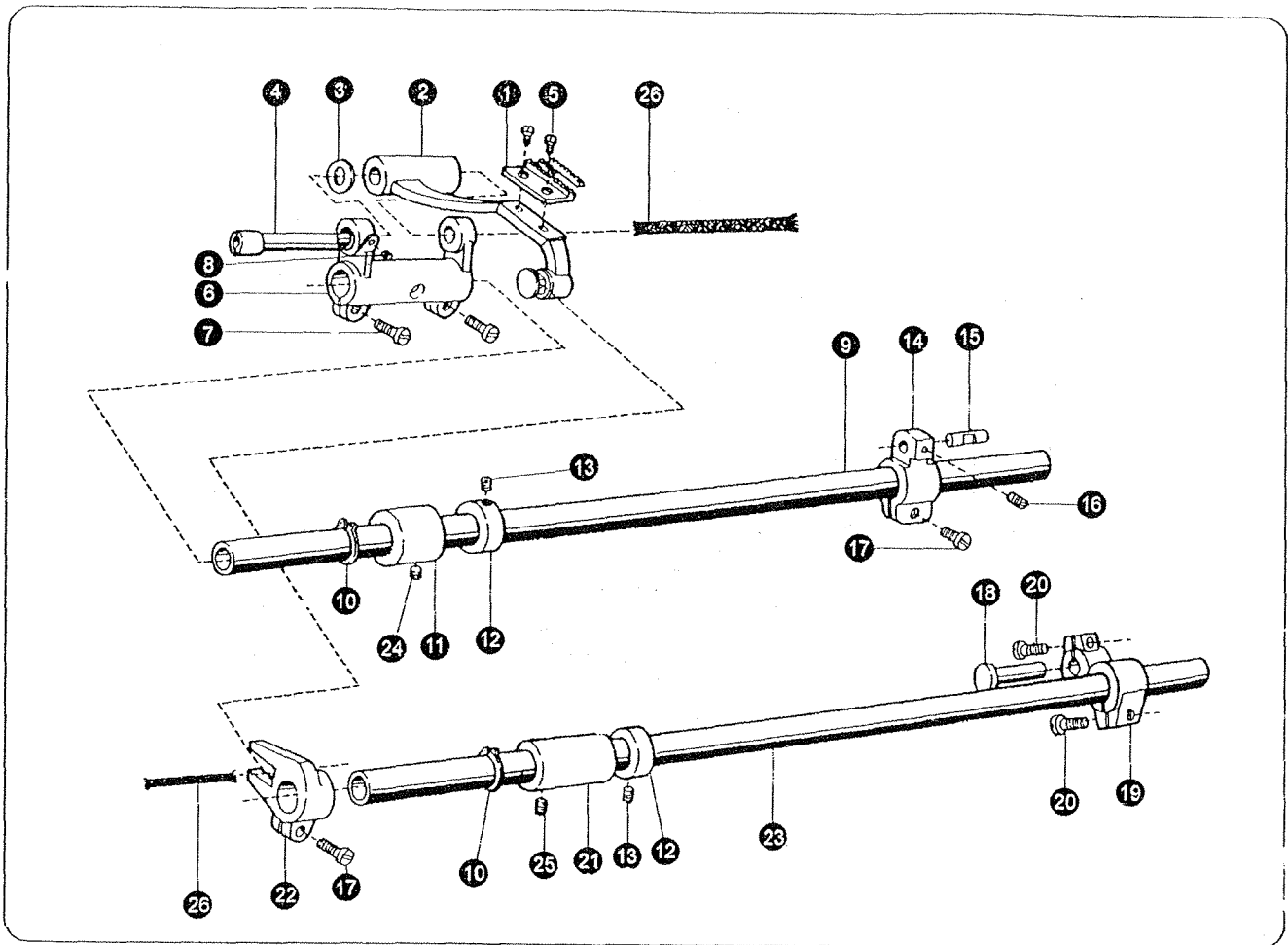

5. FEEDING AND FEED LIFTING MENCHANISM

No.	Ref. No.	Description	Pcs.		
			M	H	B
1	22T6 - 001A3	Feed dog	1		
	48T6 - 001A2	Feed dog		1	1
2	36T4 - 001A1a	Feed bar	1	1	1
3	22T6 - 001A6	Washer	1	1	1
4	36T4 - 001A2	Feed bracket shaft	1	1	1
5	22T6 - 001A4	Screw	2	2	2
6	22T6 - 001A1a	Feed rock bracket arm	1		
	48T6 - 001A1a	Feed rock bracket arm		1	1
7	22T6 - 001A1b	Screw	2	2	2
8	22T2 - 019	Screw	1	1	1
9	124T6 - 002	Feed rock shaft	1	1	1
10	GB894 - 76	C - type stop ring (ring15)	2	2	2
11	22T6 - 004	Feed rock shaft bushing	1	1	1
12	22T6 - 005B1	Collar	2	2	2
13	22T3 - 002B2	Set screw	4	4	4

No.	Ref. No.	Description	Pcs.		
			M	H	B
14	36T4 - 003	Feed rock shaft crank (right)	1		
	114T4 - 001	Feed rock shaft crank (right)		1	1
15	36T4 - 004H01	Feed link stod	1	1	1
16	36T5 - 008E5	Set screw	1	1	1
17	22T6 - 008D3	Screw	2	2	2
18	22T6 - 007	Hinge	1	1	1
19	36T4 - 017	Feed lifting rock shaft crank (right)	1	1	1
20	J0. 0. 71	Screw	2	2	2
21	22T6 - 012	Bushing for feed lifting rock shaft	1	1	1
22	36T4 - 018H1D1	Feed lifting shaft crank	1	1	1
23	124T6 - 003	Feed lifting rock shaft	1	1	1
24	22T2 - 009	Set screw	1	1	1
25	22T2 - 002	Set screw	1	1	1
26	36T4 - 001A3	Wick	2	2	2

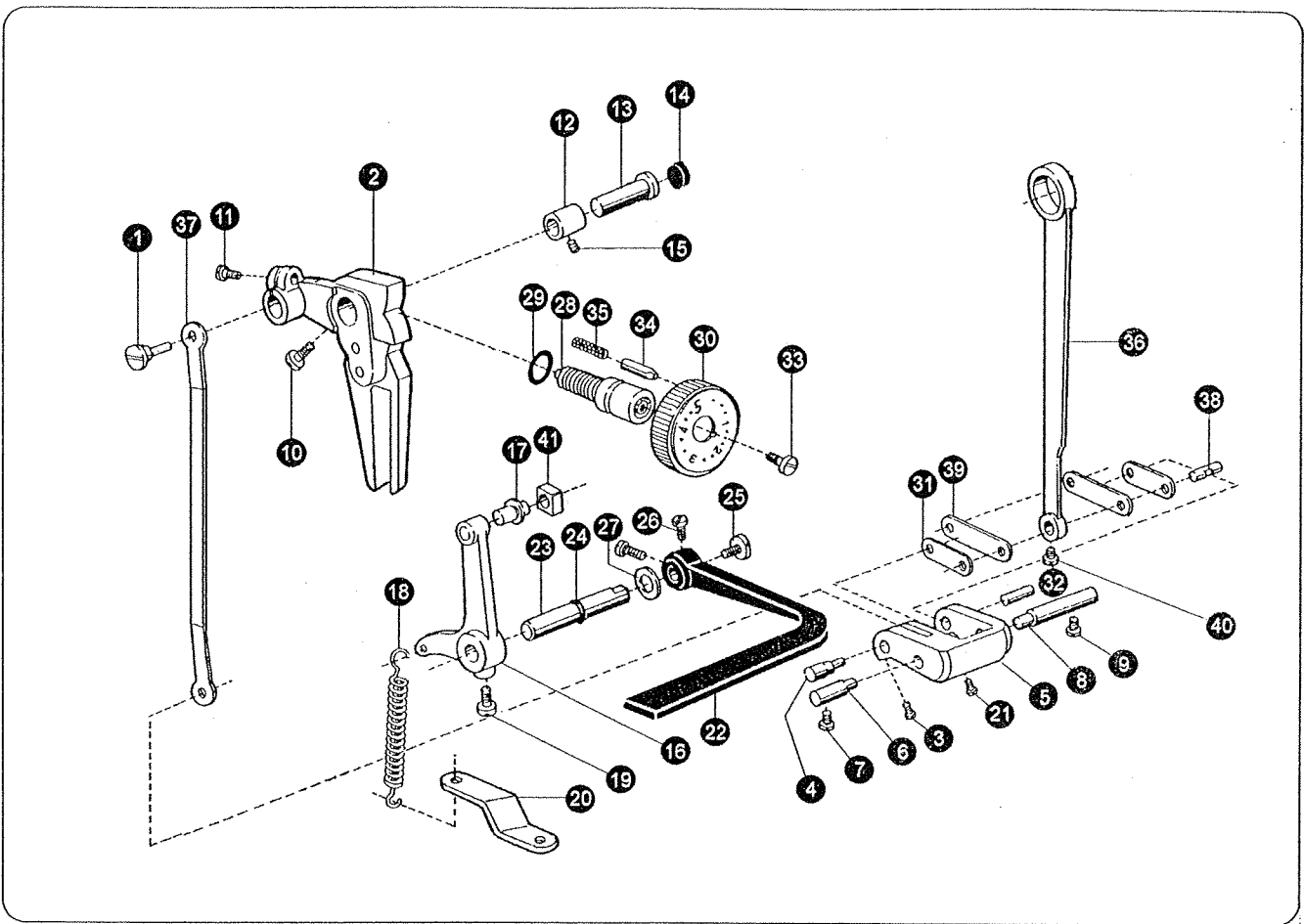

6. STITCH LENGTH REGULATING MECHANISM

No.	ref. No.	Description	Pcs.		
			M	H	B
1	36T5-001	Connectng stud	1	1	1
2	57T5-001	Feed regulator	1		
	124T5-002	Feed regulator		1	1
3	36T5-008E8	Screw	1	1	1
4	36T5-008E9	Lever link eccentric shaft	1	1	1
5	36T5-008E10	Level regulator	1	1	1
6	36T5-009H02	Pin (left)	1	1	1
7	22T6-008D3	Screw	1	1	1
8	36T5-009H01	Pin (right)	1	1	1
9	22T6-008D3	Screw	1	1	1
10	22T5-010D4	Screw of feed regulator	1	1	1
11	22T2-019	Screw	1	1	1
12	22T5-003	Feed regulator bushing	1	1	1
13	22T5-004	Feed regulator shaft	1	1	1
14	36T5-003	Rubber plug (Φ20)	1	1	1
15	22T2-002	Set screw	1	1	1
16	22T5-012E1	Backtacking crank	1	1	1
17	22T5-012E1a1	Slide block pin	1	1	1
18	57T5-004B1	Level spring	1	1	1
19	22T5-013	Set screw	1	1	1
20	57T5-005	Bracket for spring	1	1	1
21	36T5-008E7	Screw	1	1	1
22	22T5-010D1	Backtacking lever	1	1	1

No.	Ref. No.	Description	Pcs.		
			M	H	B
23	36T5-006C1a1	Backtacking lever shaft	1	1	1
24	22T5-010D2b	O-ring	1	1	1
25	22T5-010D3	Screw	1	1	1
26	22T5-010D4	Screw	2	2	2
27	22T5-011	O-ring	1	1	1
28	22T5-006C1	Feed regulator screw	1	1	1
29	124T5-001A3	O-ring for feed regulating screw	1	1	1
30	124T5-001A1-1	Knob	1		
	124T5-001A1-2	Knob		1	1
31	36T5-008E4H01	Feed rock link	1	1	1
32	36T5-008E6	Pin	1	1	1
33	22T5-006C3	Screw	1	1	1
34	22T5-008	Stopper pin	1	1	1
35	22T5-009	Spring for stopper pin	1	1	1
36	36T5-008E2	Level feed connecting rod	1	1	1
37	36T5-008E3	Feed regulator link	1	1	1
38	36T4-004H02	Link shaft	1	1	1
39	36T5-008E4H02	Feed rock arm link	2		
	114T5-003	Feed rock arm link		2	2
40	36T5-008E5	Screw	1	1	1
41	22T5-012E1a2	Crank slide block	1	1	1

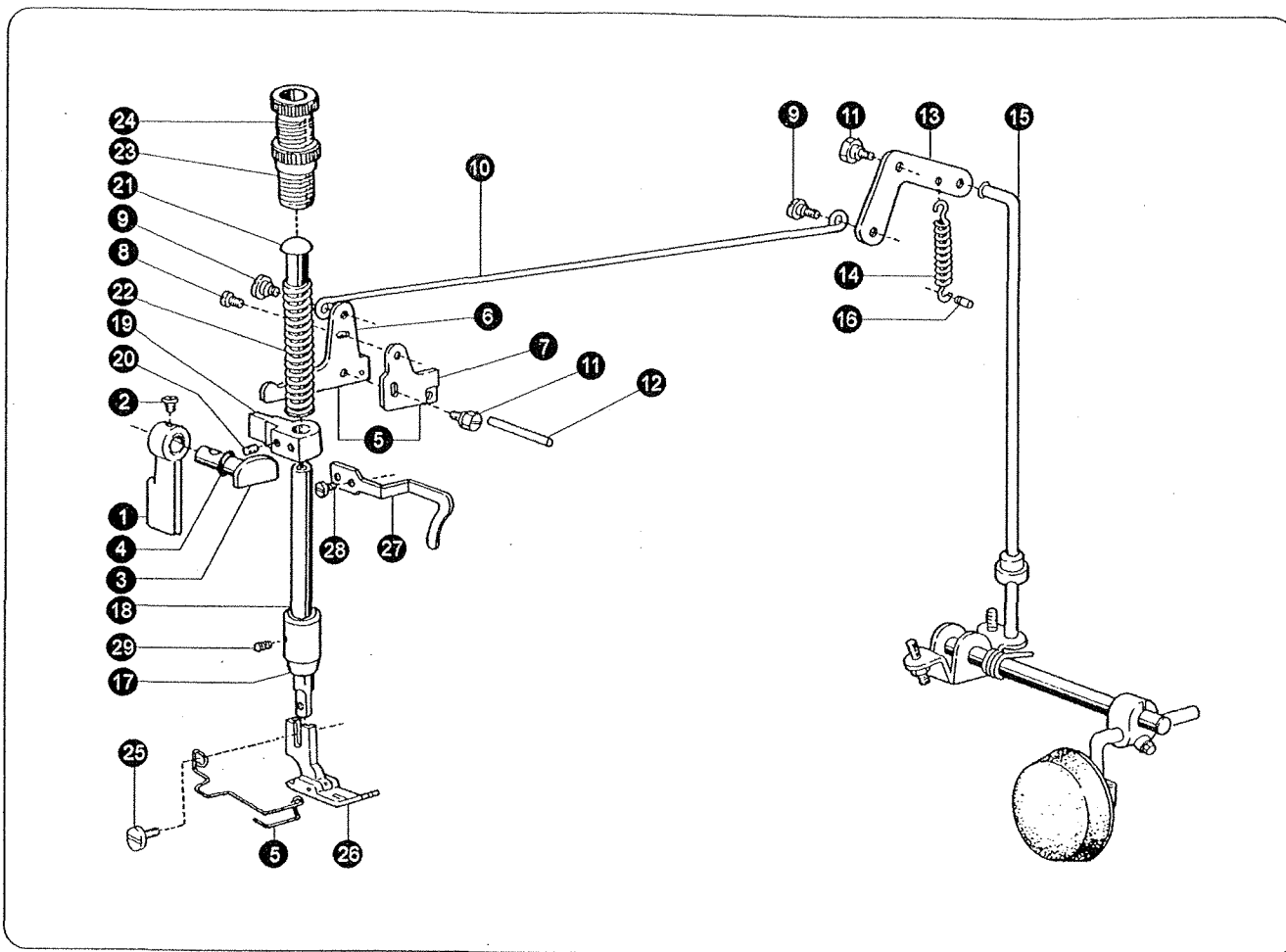

7. PRESER FOOT MECHANISM

No.	Ref. No.	Description	Pcs.		
			M	H	B
1	22T7 - 001A	Presser bar lifter	1	1	1
2	22T7 - 006	Set screw	1	1	1
3	22T7 - 002	Presser bar lifter	1	1	1
4	GB1235 - 76	Oil seal for presser bar	1	1	1
5	57T7 - 002	Presser foot spring	1	1	1
6	22T7 - 004B1a	Knee lifter lever(left)	1	1	1
7	22T7 - 004B1b	Tension releasing cam	1	1	1
8	22T7 - 004B1c	Screw	1	1	1
9	22T7 - 004B2	Hinge screw	2	2	2
10	22T7 - 004B3	knee lifter rod	1	1	1
11	22T7 - 005	Bolt for tension releasing cam	1	1	1
	22T7 - 005	Screw	1	1	1
12	22T7 - 006	Tension releasing pin	1	1	1
13	22T7 - 007C1	Knee lift lever (right)	1	1	1
14	22T7 - 007C2	Spring for knee lifter lever(right)	1	1	1
15	22T7 - 007C3	Knee lifter connecting rod	1	1	1

No.	Ref. No.	Description	Pcs.		
			M	H	B
16	22T7 - 008	Pin for spring	1	1	1
17	22T7 - 009	Presser bar bushing	1	1	1
18	22T7 - 010	Presser bar	1	1	1
19	22T7 - 011D1	Presser bar lifting bracket	1	1	1
20	22T1 - 013	Set screw	1	1	1
21	22T7 - 012	Presser bar guide	1	1	1
22	22T7 - 013	Presser spring	1		
	48T7 - 002	Presser spring		1	1
23	22T7 - 014E1	Presser regulating thumb screw	1	1	1
24	22T7 - 014E2	Lock nut	1	1	1
25	22T7 - 015	Set screw	1	1	1
26	22T7 - 017F	Presser foot complete	1		
	48T7 - 003A	presser foot complete		1	1
27	22T2 - 009	Slack thread regulator	1	1	1
28	22T7 - 004	Screw	1	1	1
29	22T - 013	Set screw	1	1	1

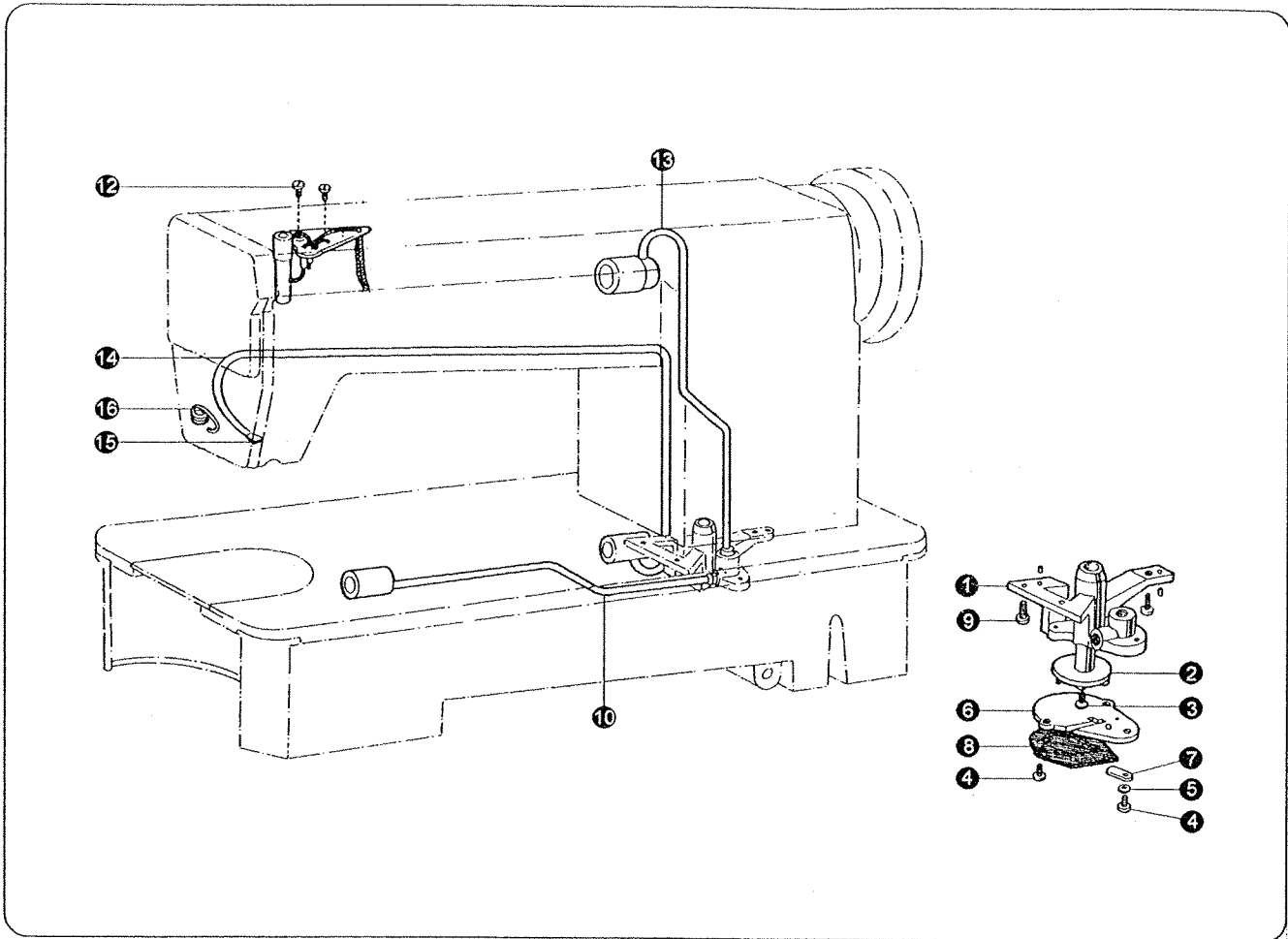

8. LUBRICATION MECHANISM

No.	Ref. No.	Description	Pcs.		
			M	H	B
1	22T8 -001	Oil pump body	1	1	1
2	22T8 -002	Oil pump impeller	1	1	1
3	22T8 -003	Screw	1	1	1
4	22T8 -004	Screw	3	3	3
5	22T8 -005	Spring washer	1	1	1
6	22T8 -006	Oil pump filtering plate	1	1	
	78T8 -001	Oil pump filtering plate			1
7	22T8 -007	Oil adjusting plate	1	1	1
8	22T8 -008A	Oil pump screen complete	1	1	1

No.	Ref. No.	Description	Pcs.		
			M	H	B
9	22T8 -009	Screw	3	3	3
10	22T8 -010B	Oil pipe for hook shaft	1	1	1
11	22T8 -011C	Oil braid fitting plate	1	1	1
12	22T7 -015	Screw	2	2	2
13	22T8 -013D	Oil pipe for arm shaft	1	1	
	78T8 -002A	Oil pipe for arm shaft			1
14	22T8 -014	Oil returning pipe	1	1	1
15	22T8 -015	Felt pouch for return oil filter	1	1	1
16	36T10 -002	Oil returning pipe holder	1	1	1

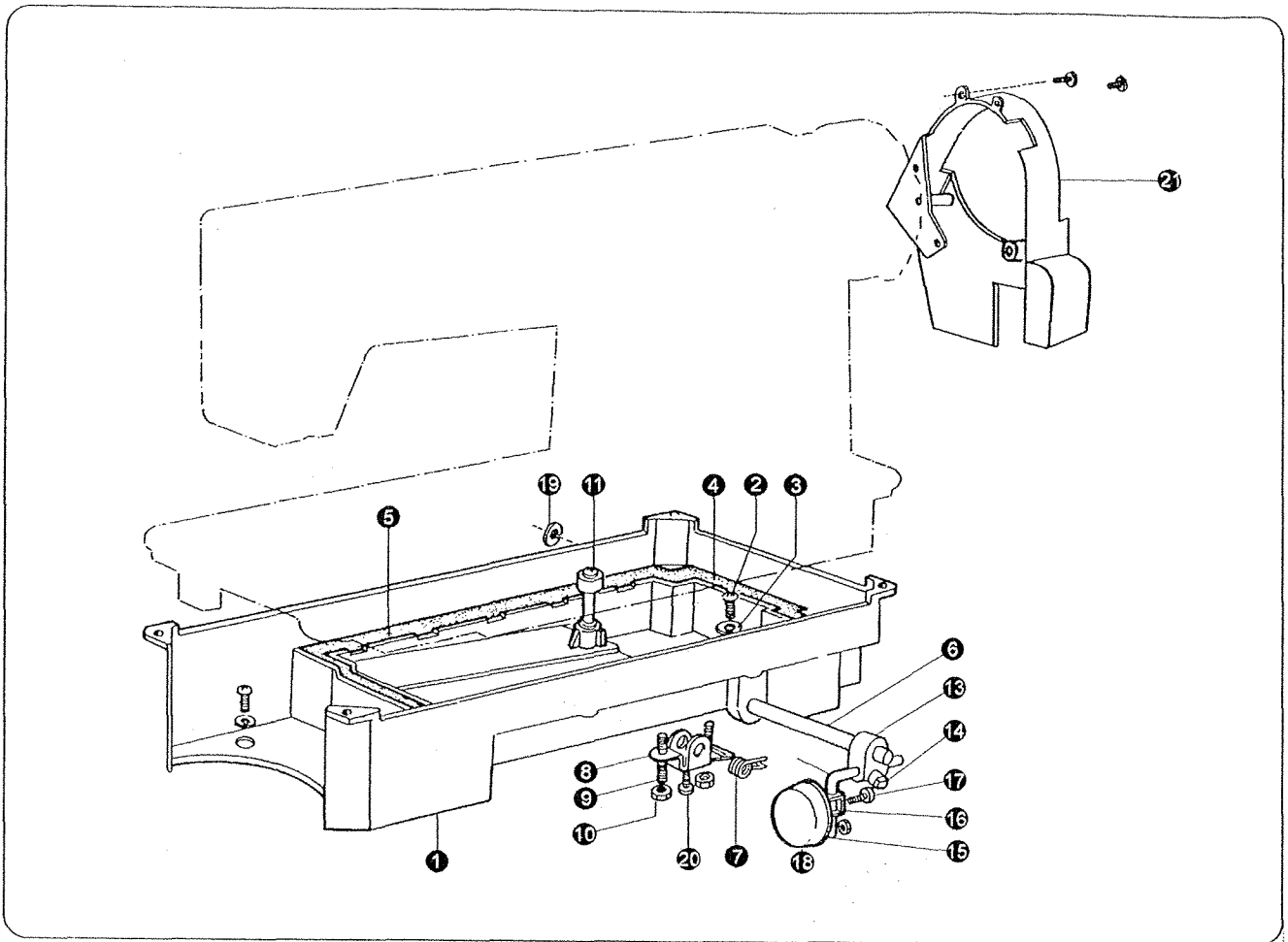

9. OIL RESERVOIR AND OTHER ACCESSORIES

No.	Ref. No.	Description	Pcs.			No.	Ref. No.	Description	Pcs.		
			M	H	B				M	H	B
1	22T9-001A1	Oil reservoir	1	1	1	12	22T9-003B2	Knee lifter bell crank	1	1	1
2	22T9-001A2	Oil drain screw	2	2	2	13	22T9-001B3	Knee lifter bell crank joint	1	1	1
3	22T9-001A3	Washer	2	2	2	14	GB5781-86	Set screw	2	2	2
4	22T9-001A4	Gasket for oil reservoir(S)	1	1	1	15	22T9-003B5	Knee lifter plate	1	1	1
5	22T9-001A5	Gasket for oil reservoir(B)	1	1	1	16	22T9-003B6	Bracket for knee lifter plate	1	1	1
6	22T9-001A6	Hinge pin for knee lifter lever	1	1	1	17	22T9-003B7	Set screw	1	1	1
7	22T9-001A7	Back spring for knee lifter	1	1	1	18	22T9-003B8	Pat for knee lifter plate	1	1	1
8	22T9-001A8	Knee lifter stop bracket	1	1	1	19	GB896-76	C-type stop ring	1	1	1
9	22T9-001A9	Adjusting screw	2	2	2	20	22T9-036	Screw	1	1	1
10	22T9-001A10	Lock nut	2	2	2	21	22T9-004C	Belt cov	1	1	1
11	22T9-003B1	Knee lifter lifting rod	1	1	1						

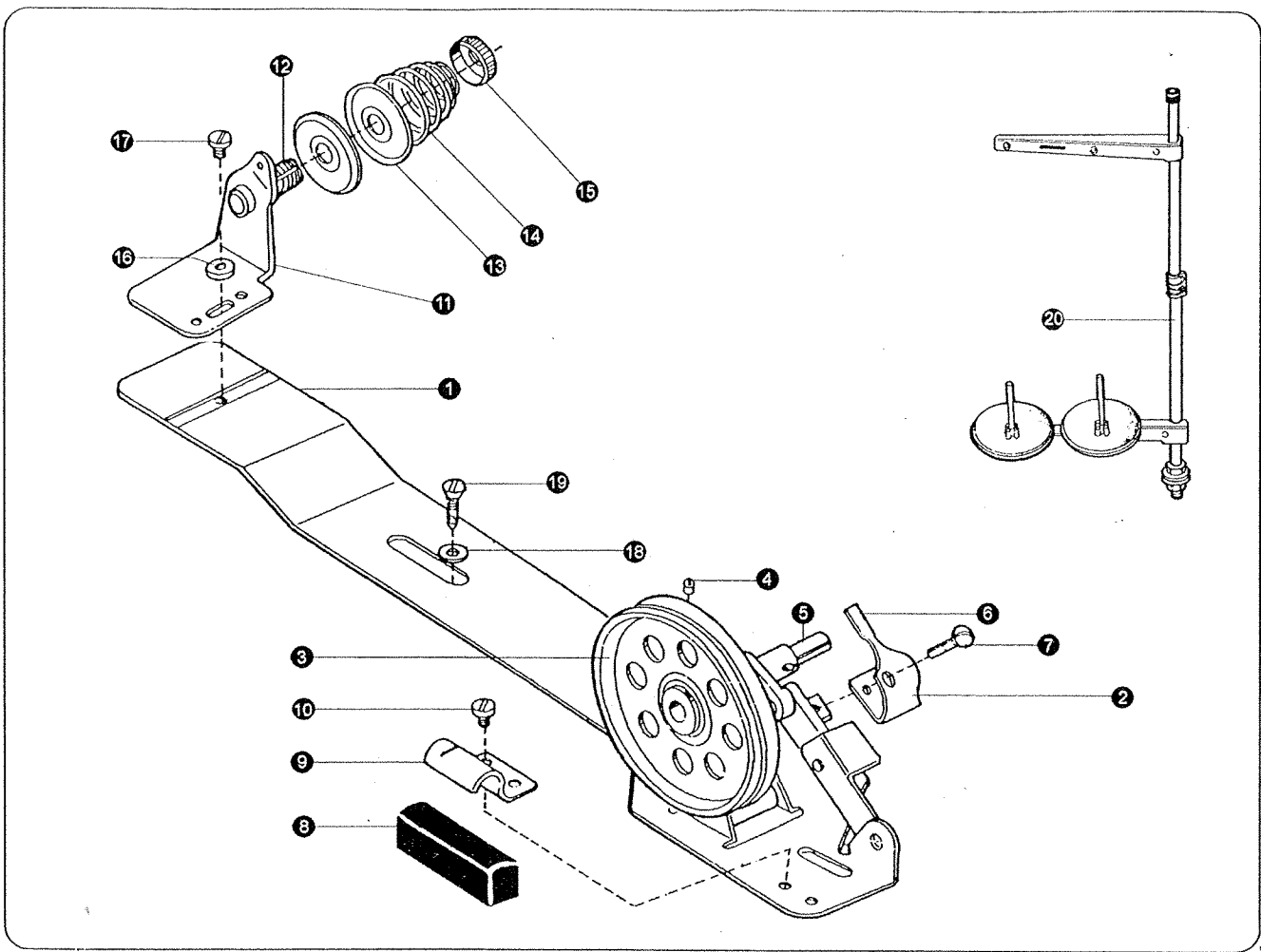

10. BOBBIN WINDER. SPOOL STAND MECHANISM

No.	Ref. No.	Description	Pcs.		
			M	H	B
1	6F0 - 001A	Bobbin winder base	1	1	1
2	6F0 - 001A6a	Bobbin winder stop latclever set	1	1	1
3	6F0 - 002	Bobbin winder pulley	1	1	1
4	01/B112	Screw	1	1	1
5	6F0 - 003	Bobbin winder spindle	1	1	1
6	6F0 - 004 - 1	Bobbin winder stop latch	1	1	
	6F0 - 004 - 2	Bobbin winder stop latch			1
7	6F0 - 005	Adjusting screw	1	1	1
8	6F0 - 006	Stoper block	1	1	1
9	6F0 - 007	Stoper block clamp	1	1	1
10	6F0 - 008	Set screw	1	1	1

No.	Ref. No.	Description	Pcs.		
			M	H	B
11	6F0 - 009B1b1	bobbin winder tension bracket	1	1	1
12	17T7 - 017	Bobbin winder tension stud	1	1	1
13	22T1 - 012F5	Bobbin winder tension discs	2	2	2
14	22T1 - 012F3	Bobbin winder tension spring	1	1	1
15	J2. 2. 7	Tension stud nut	1	1	1
16	BQ10021	Washer	1	1	1
17	22T2 - 004	Tension bracket screw	1	1	1
18	BQ10021	Washer	2	2	2
19	GB99 - 76	Wood screw	2	2	2
20	GXJ - 2	Spool stand	1	1	1

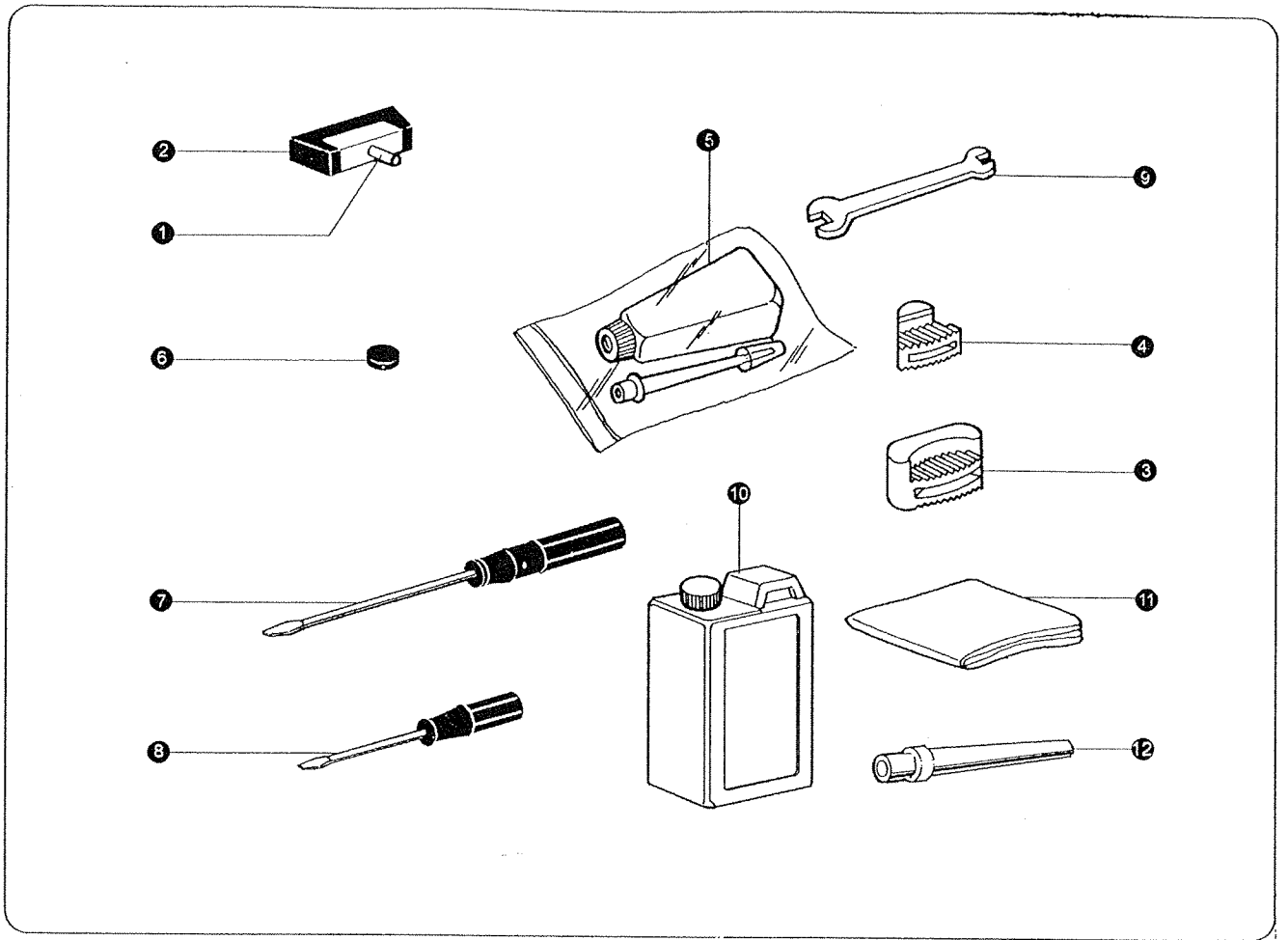

11. ACCESSORIES

No.	Ref. No.	Description	Pcs.		
			M	H	B
1	22T9-007F1	Hinge of machine head	2	2	2
2	22T9-007F2	Hinge socket of machine head	2	2	2
3	22T9-009	Rubber cap (Big)	2	2	2
4	22T9-010	Rubber cap (small)	2	2	2
5	22T9-011	Oil pot	1	1	1
6	22T9-012	Magnet	1	1	1

No.	Ref. No.	Description	Pcs.		
			M	H	B
7	22T9-013	Screw driver (large)	1	1	1
8	22T9-015	Screw driver (small)	1	1	1
9	22T9-016	Double end wrench	1	1	1
10	22T9-017	Oil can	1	1	1
11	22T9-018	Vinyl cover	1	1	1
12	124T9-002	Head prop pole	1	1	1

